

Vega505EE

SystemRoMedic™

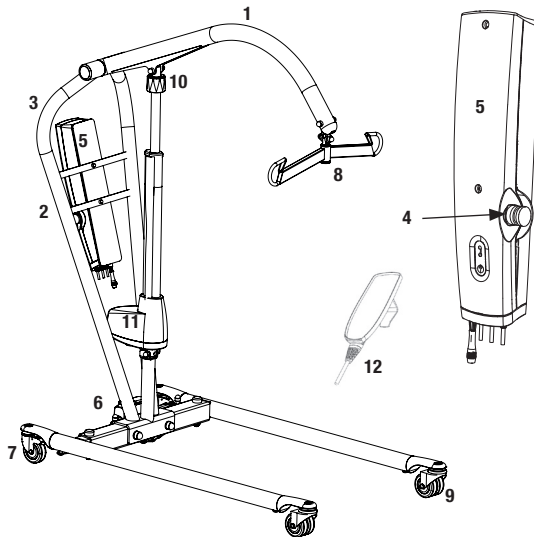

1. Lift arm
2. Mast
3. Handlebar
4. Emergency stop
5. Control box / Battery pack
6. Motor for base-width adjustment
7. Rear castors with brakes
8. Sling bar with safety latches
9. Front castors
10. Emergency lowering
11. Motor/actuator for lift arm
12. Handset

SWL: 230 kg / 505lbs

Mobile lift Vega505EE has been developed to meet most lifting needs in combination with the right accessories. It is a lift that can lift patients in a seated or supine position. Vega505EE is made largely of steel.

Handicare's SystemRoMedic product series includes a range of lifts, slings and other accessories. SystemRoMedic adopts a holistic approach to patient transfers and is organized in four categories: transfer, positioning, support and lifting.



Functional inspection

Visual inspection

Inspect lift functions regularly. Check to ensure that material is free from damage.

Before use:

Ensure that the product is correctly assembled.

Check slingbar connection and safety latch function.

Check lift and base-width movement.

Check to ensure that the actuator is correctly installed.



Always read the manual

Always read the manuals for all assistive devices used during a transfer.

Keep the manual where it is accessible to users of the product.

The lift may only be used by persons who have received instruction in the operation of the lift.

Table of contents

Assembly	3
- Final inspection	4
Using the product	5
- Important information	5
- Safe working load	5
- Charging batteries	6
- Handset	6
- Emergency stop	7
- Emergency lowering	7
- Trouble shooting	7
Accessories	8
Maintenance	9
Technical information	10
- Dimensions Vega505EE	11-12

Assembly

Check to ensure that the following components are included:

Mast and lift arm, actuator, slingbar, control box, handset and cover for cables. Undercarriage with base-width adjustment motor, screws, washers, nuts and screw covers. Manual and charger.

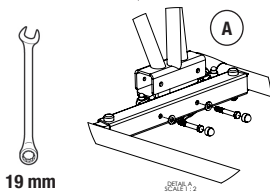
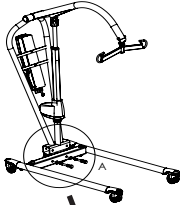
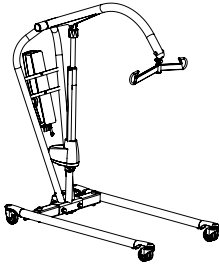

Insert the mast onto the base. Assemble according to illustration A and tighten (>60 Nm). Place the screw covers over the screws.

Connect the cables to the kontrollbox. Cable to actuator (motor on mast) to outlet 1, and cable for base-width adjustment motor to outlet 2. Mount the cover for the cables using the two screws.

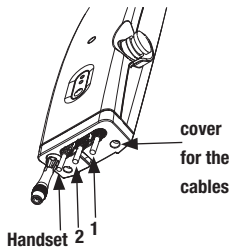

Release the emergency-stop mechanism and perform a final inspection (see final inspection).

Final inspection

Check to ensure that no parts have been left in the packaging.
Inspect the lift for signs of wear and damage.
Check all four castor wheels and castor wheel locks.
Check all connections and fixtures including screws and bolts.

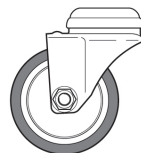

Check the emergency stop function by depressing the emergency stop, and then pressing either the up or down button. If nothing happens when the up or down buttons are pressed, the emergency stop is functioning properly.

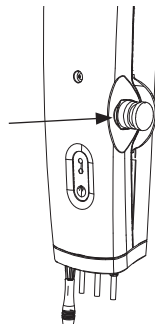

Grasp the handset, press the up button and run the lift arm all the way up. Then, press the down button and run the lift arm all the way down.

Test base-width adjustment function. Press the button for base-width adjustment to widen the base fully, and then press the other button to narrow the base again.

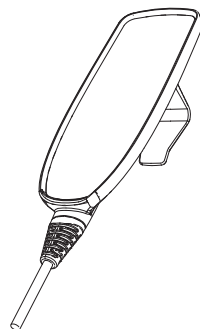

Test lift function by lifting a person (not a patient) using an approved sling. At the same time, check the emergency lowering function with someone on the lift. See section on Emergency lowering.

If the lift is functioning correctly, connect the charger and check to ensure that the charging lamp on the control box lights up.

NOTE!



Before the lift is used for the first time, it must be charged for at least 4 hours. See section on charging batteries.

Keep the manual where it is accessible to users of the product.

Using the product



Important Information

- The lift must be assembled according to the assembly instructions provided with the lift.
- The lift may only be used indoors and on a level floor.
- Lifting accessories must be properly fitted and tested in relation to the patient's needs and functional ability.
- Do not leave the patient unattended during a transfer situation.
- Under no circumstances may max. load be exceeded. See section on Safe working load.
- Never move the lift by pulling on the actuator! 
- The lift must not come in direct contact with water.
- The lift must not be charged in a wet room.
- To ensure optimal function, the lift must be inspected regularly. See section on Maintenance.
- Warranty applies only if repairs or alterations are done by an authorized technician.
- Note that there is a pinch point between the manual emergency lowering mechanism and the lift arm when the lift arm is in its highest and lowest positions. 

Safe working load

Different products on the same lift system (lift unit, slingbar, sling, scales and other lifting accessories) may have different allowable safe working loads. The lowest allowable safe working load always determines the safe working load of the assembled system. Always check the safe working loads for the lift and accessories before use. Contact your dealer if you have any questions.

Charging batteries

A tone when using the lift indicating that the batteries need recharging.

Lock the castors when charging the battery.

Make sure the emergency stop button is not pressed in.

Charging procedure:

1. Connect the charger to the charger cable leading from the underside of the control box.
2. Connect the charger to a power outlet (100-240 V AC).
3. When the charger is connected, the control box lamp indicates a yellow light.

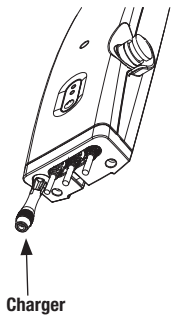

Charger

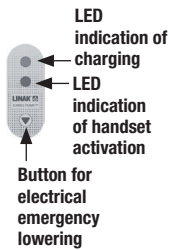

NOTE!

Before the lift is used for the first time, it must be charged for at least 4 hours.

Charge batteries regularly for maximum longevity. We recommend daily charging when the lift is in daily use.

The emergency stop button must be pulled out during charging.

Handset

Raising/lowering the lift arm

Symbol indicate direction of travel.

Motion stops as soon as the button is released.

Widening/narrowing the base

Markings on the buttons indicate function.

Motion stops as soon as the buttons are released.

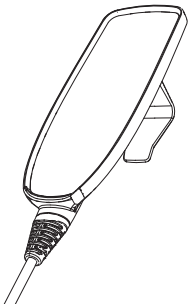



Emergency stop

To activate emergency stop:

Depress the red emergency stop button on the control box.

Resetting:

Turn the button in the direction of the arrows until the button pops out.

To prevent battery discharge, we recommend that the emergency-stop button is pressed in when the lift is not in use.

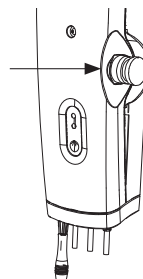

Emergency lowering

Manual emergency lowering:

For manual emergency lowering, turn the round plastic knob on the actuator clockwise.

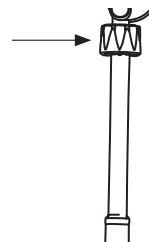

Electrical emergency lowering:

For electrical emergency lowering, use the down button on the control box.

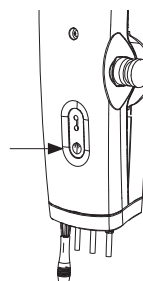

Trouble shooting

If the lift or base-width adjustment cannot be activated, check the following:

- That the emergency stop button is not pressed in.
- That all cables are properly and securely connected. Pull out the contact and plug it in again firmly.
- That battery charging is not in progress.
- That the battery is charged.

If the lift is not working properly, contact your dealer.

If the lift makes unusual noises:

- Try to determine the source of the sound. Take the lift out of operation and contact your dealer.

Accessories

SystemRoMedic

Slings

SystemRoMedic offers a wide variety of functional and comfortable high quality lifting slings adapted to meet the different requirements of all kinds of lifting situations and users. The lifting slings are available in four different materials and in sizes ranging from XXS to XXL. All models are safe and very easy to use.



Sling bars

SlingBar is SystemRoMedic's aluminium sling bar. It's available in three different widths and is therefore suitable in most lifting situations and for users of all sizes.

SlingBar S article no.: 01-70200001

SlingBar M article no.: 01-70200002

SlingBar L article no.: 01-70200003



SideBar article no.: 01-70200013

SwiftHook for sling bar article no.: 01-70200008



StretcherBar, article no.: 01-70200006, and StretcherSling, article no.: 01-46502007, for lifting in supine position.

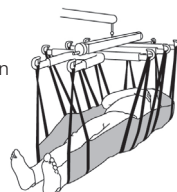

Scale

SystemRoMedic's scales Charder MHS2500 are used together with stationary or mobile lifts for weighing of users.

Article no.: 01-70100002

Article no.: 01-70200003



Assistive devices for positioning

SystemRoMedic includes a wide range of functional, comfortable, high-quality assistive devices for positioning that can be adapted for different types of lifting and for patients with different needs.

Ready for life

Sling bar

The Ready for life four-point slingbar, Sling bar RFL X4, is designed to provide more space in the sling, for example, for obese and/or pain-sensitive users. Article no.: 70200017



Maintenance

The lift must undergo thorough inspection at least once per year. Inspection must be performed by authorized personnel and in accordance with Handicare's service manual.

Repairs and maintenance may only be done by authorized personnel using original spare parts.



Spent batteries are to be left at the nearest recycling station. Spent batteries can also be returned to Handicare or a Handicare dealer for recycling.

Cleaning/disinfection

Clean the lift with warm water or rubbing alcohol and ensure that the castor wheels are free of dirt and hair. Do not use cleaning agents containing phenol or chlorine, as this may damage the material.

Storage

If the lift is not to be used for some time or e.g., during transport, we recommend that the emergency stop button be pressed in. Store the lift at a temperature above freezing point and not exceeding normal relative humidity (about 60%).

Service agreements

Handicare offers the possibility of service agreements for maintenance and regular testing of your mobile lift. Contact your local Handicare representative.

Technical information

Lifting speed:	37 mm/s without load.
Charger:	Max. 400mA
Batteries:	24V, 2,9 Ah valve-regulated, sealed, lead accumulator (gel-type batteries)
Motor (mast):	DC 24V, 9,7 Amp. IP X4. Operationtime: 10% at maximum continous operation of 2 minutes, maximum 5 cycles per minute. Push: 10 000N.
Motor (base):	24V, 2,2 Amp. IP X4. Operationtime: 10% at maximum continous operation of 2 minutes, maximum 5 cycles per minute. Push: 1500N.
Material:	Steel
Emergency lowering:	Mechanical and electrical
Castors:	Front 75 mm, back 75mm
IP class:	IP X4
Weight:	42,8 kg
Sound level:	With load: upwards: 43 dB(A) downwards: 44 dB(A).
Expected lifetime:	10 years
Operating forces buttons on handset:	4 N

The lift complies with the requirements of Council Directive 93/42/EEC of 14. June 1993 concerning medical devices.



The device is intended for indoor use.



Type B, according to the degree of protection against electric shock.

Dimensions Vega505EE

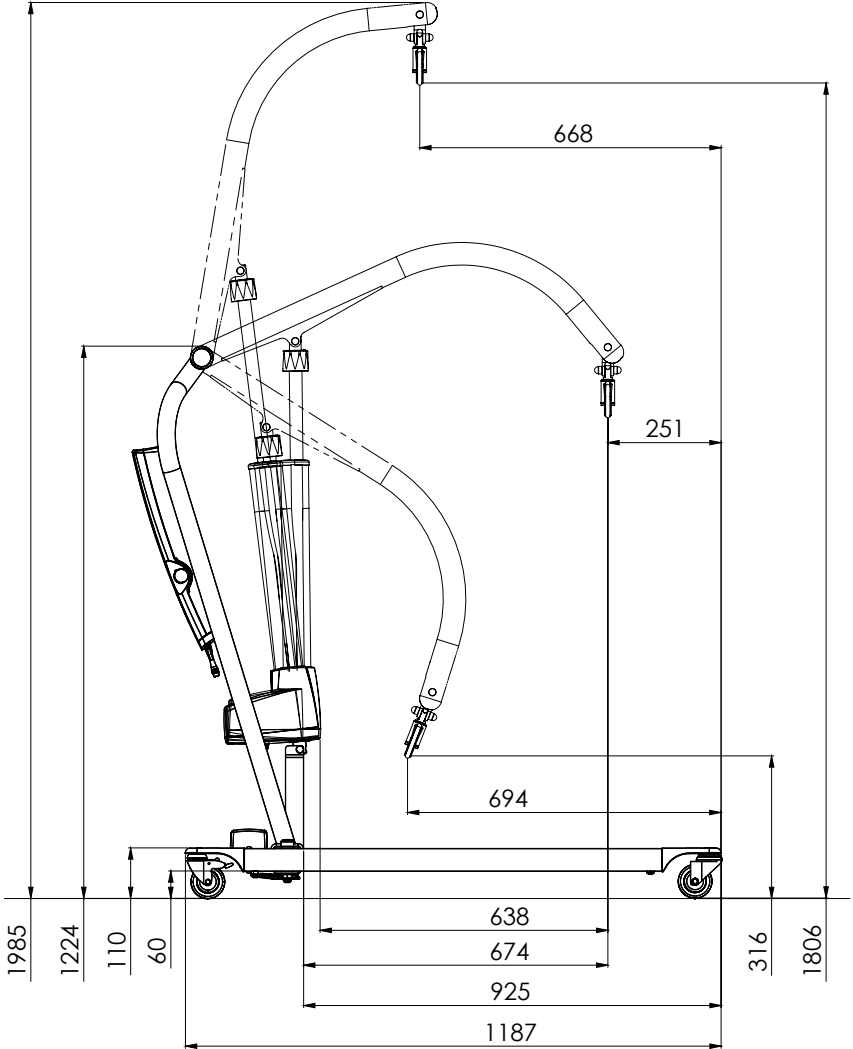

All measurement are in mm

Dimensions Vega505EE

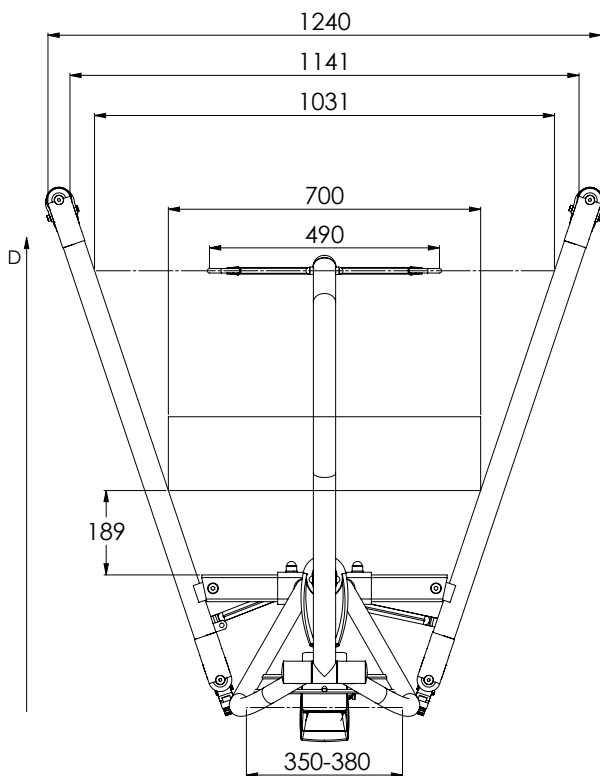

All measurement are in mm

- Turning diameter is 1230 mm
- The total weight of the lift is 42,8 kg
- The weight of the heaviest part is 25,8 kg
- D is movement in forward direction

SystemRoMedic™

For 25 years SystemRoMedic have applied themselves wholeheartedly to developing smart and easy-to-use assistive devices for easy transfers and to making life and work easier for both patients and personnel in the care sector.

Experience, innovation and training are the basis for SystemRoMedic, a total solution for every imaginable transfer situation.

Transfer: products for moving patients between locations.

Positioning: products for repositioning in the same location.

Support: products that provide mobility support.

Lifting: products adapted for lifting.

The philosophy behind SystemRoMedic is to prevent occupational injuries while improving the patient's sense of independence and dignity. Through a combination of training and a complete range of transfer-assistive devices, SystemRoMedic offers the means to improving both the work environment and the quality of care while enabling significant cost savings.

SystemRoMedic's mission, is to help people, has always been, and will continue to be, the driving force of innovation. They love easy transfers.



P O Box 4791 Ferndown Dorset BH22 9WB

Tel: 07857 603031 Fax: 01202 877240

Email: info@amilakesouthern.co.uk